

Panther 6x6_CA-5

Edition 1.0 / 01-06-2005



BASIC SPECIFICATION

Chassis:

- ROSENBAUER Motors RBM 36.705 6x6
- Caterpillar C18 EURO 3; 518 kW / 705 HP / in-line 6-cylinder, turbo charged diesel engine.
- Wheelbase 4800 + 1600 mm
- Electric system 24 V
- Twin Disc fully automatic transmission with torque converter and integral transfer case
- Twin Disc Power Divider for independent pump and roll
- Dual circuit brake system with ABS; ECE compliant
- LEFT or RIGHT off-center ; ZF power steering; ECE compliant
- ROSENBAUER 2 door, MAXVIEW aluminium cab, ECE R29 compliant, seating capacity 1+5
- High mobility on / off road tires 16.00 R20 (opt. 24 R21)
- Spare wheel (temporary mounted)
- Fuel tank 300 litres; ECE compliant
- Kessler, permanent all wheel drive axles with longitudinal and transversal differential locks. Permissible GVWR max. 3x13 ton.
- Acceleration 0 – 80 kph depending on GVW within 28 to 32 sec.
- Top speed approx. 115 km / h

Fire fighting system and superstructure:

- ROSENBAUER R 600 water pump, rated up to 7000 l/min
- ROSENBAUER RVMA 500 fully automatic foam proportioning system mechanically operated
- Ergonomic one man control cab layout
- Optional structural fire fighting side panel
- ROSENBAUER RM 60 E, roof turret up to 7000 l/min
- ROSENBAUER RM 8E or RM 15 E, bumper turret up to 1500 l/min
- Two (2) quick attack, electric rewind hose reels
- Self protection nozzles
- Polypropylene - Water tank up to 13.000 l useable
- Polypropylene - Foam tank up to 1.560 l useable
- Dry chemical system up to 250 kg foam compatible dry powder
- Equipment locker made of glass fibre re-inforced polyester material
- Rear engine/equipment compartment w/ coach type doors
- Emergency lighting and PA/siren system
- Optional High Reach Extendable Turret (HRET)

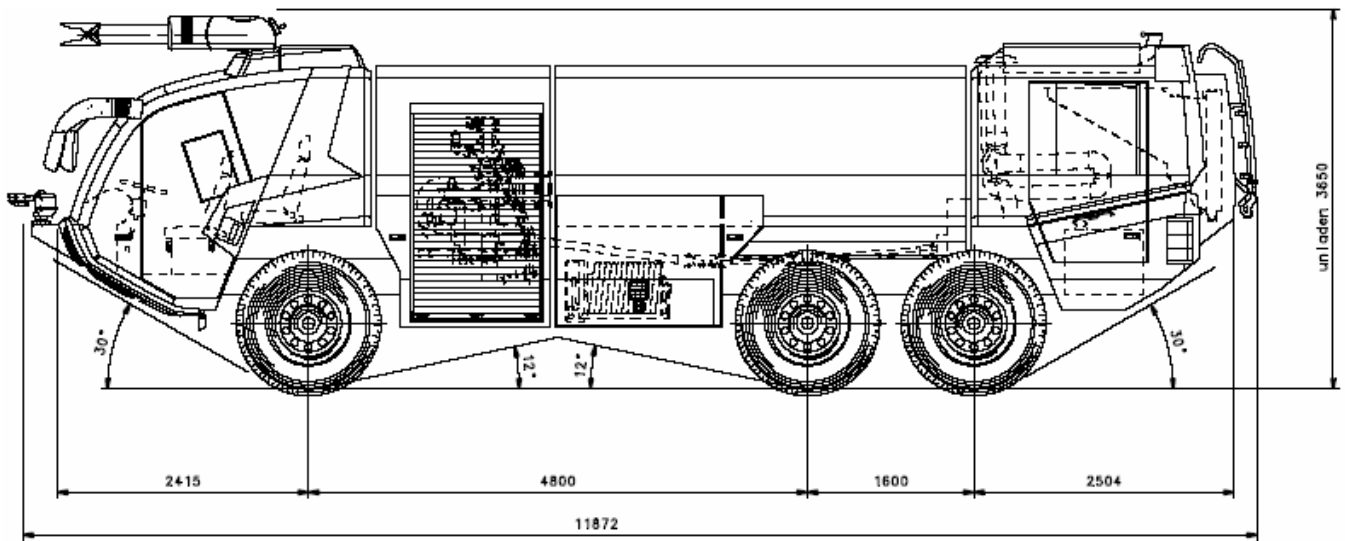

Tel.: + 43 (0)70 6794-0
Fax :+ 43 (0)70 6794-83
E-Mail: office@rosenbauer.com
Internet: www.rosenbauer.com

Rosenbauer International Aktiengesellschaft
4060 Leonding, Paschinger Straße 90 AUSTRIA

Text and illustrations are not binding. The illustrations may show optional extras only available at extra charge. Rosenbauer International Aktiengesellschaft also reserve the right to carry out alterations of the appliance's design, which will improve or enhance its operational characteristics and/or performance.